

### RPI HEADER

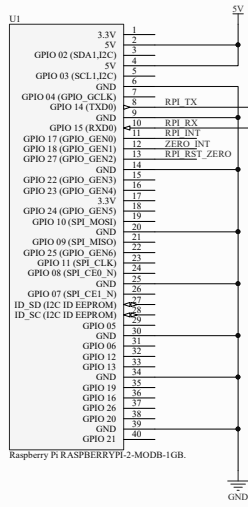

### POWER SUPPLY

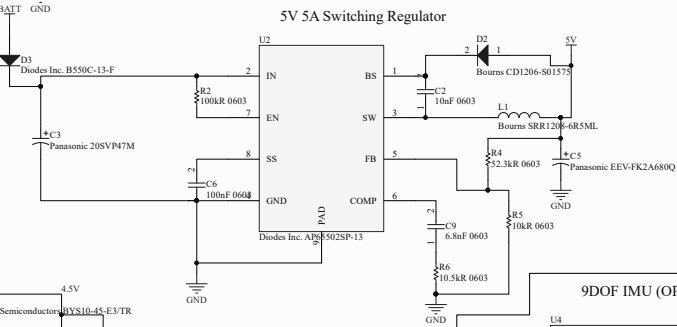

### MOTOR CONTROLLERS

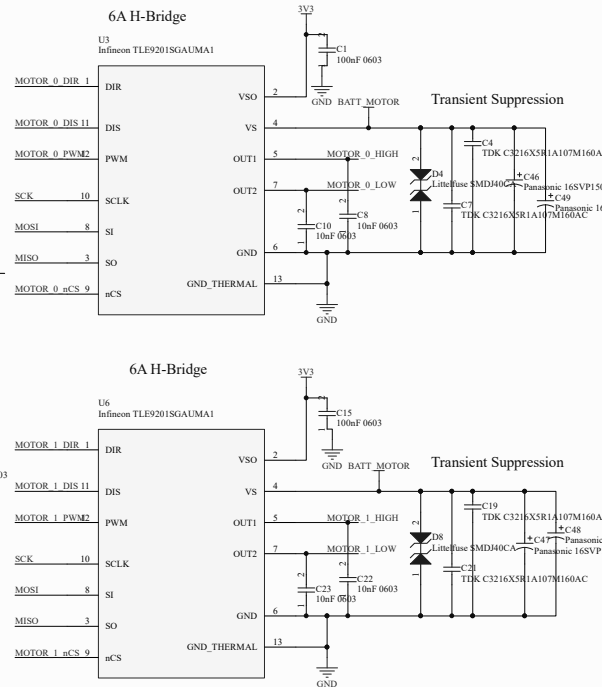

### Reverse + Flyback



### 9DOF IMU (OPTIONAL, DO NOT PLACE)

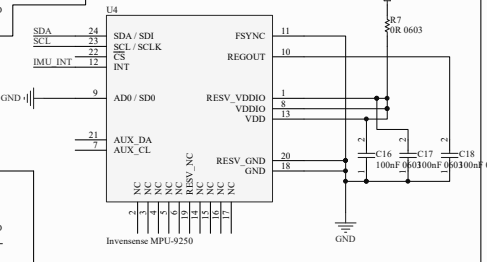

### LEDS

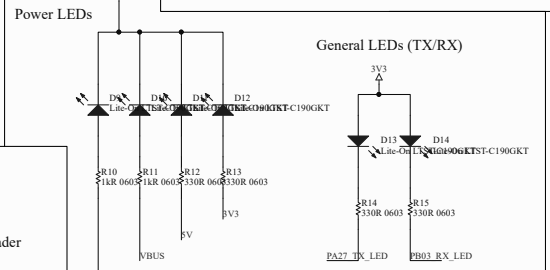

### MICROCONTROLLER (Functionally Arduino Zero)

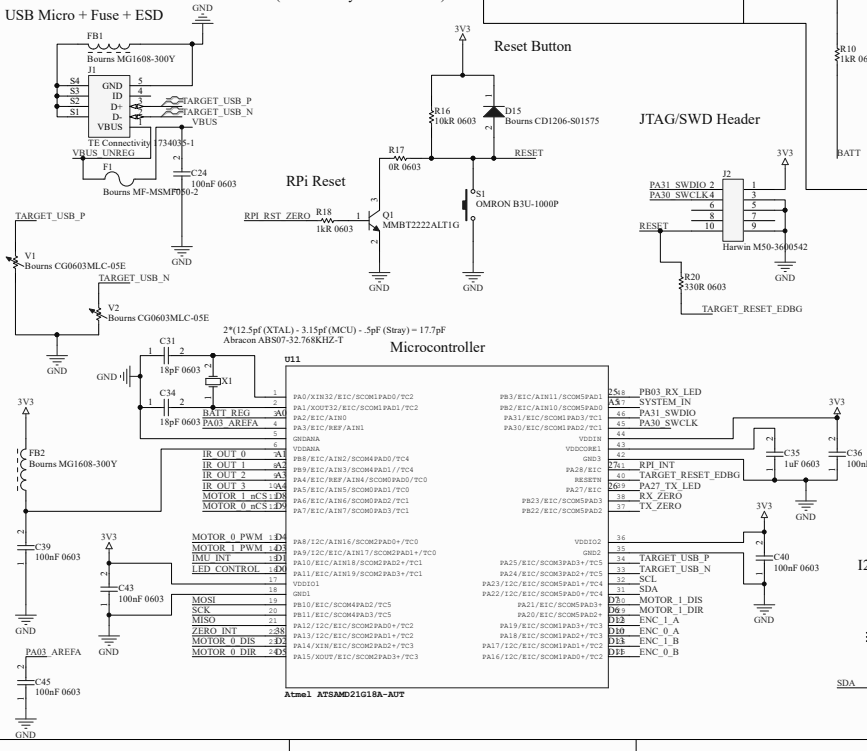

### ADDRESSABLE RGB LEDS

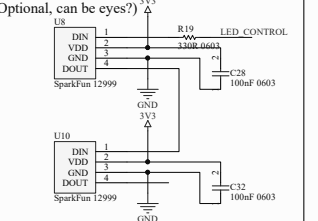

### MOTORS + ENCODERS

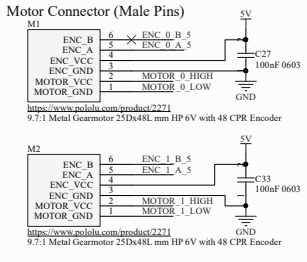

### Level Shifter 5V to 3.3V

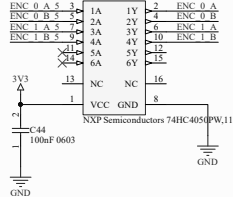

### IR SENSORS

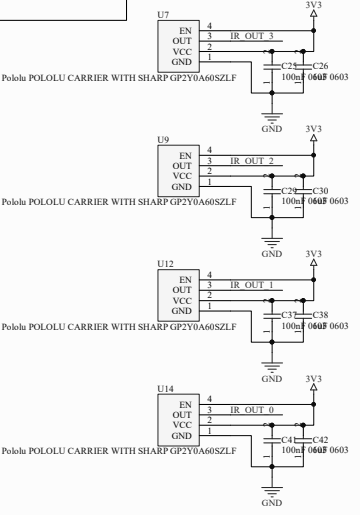

### ECCS 452 DOGBOT

Size	Number	Revision
C	V1-110316	A
Date:	11/03/2016	Sheet 1 of 1
File:	DOGBOT_MAIN.SchDoc	Drawn By: Jonathan Zarzer